



## Description

Altech's Decade Series Wall Pack LED fixture is perfect to replace all of your traditional HID and CFL wall packs. The Anti-UV Polycarbonate Lens will not crack or yellow under sunlight.



Not all product variations listed on this page are DLC qualified. To ensure that a specific model is qualified, visit [www.designlights.org/search](http://www.designlights.org/search)

## Applications

Wet Environments  
Security Lighting

Tunnel Roads  
Alleyways

Wall-side Pathways  
Underground Parking

## Specs

Efficacy 130 lm/W  
Input Voltage 100-277V  
Finish Bronze

## Details

IP Rating IP65  
Materials Aluminum  
Lens Anti-UV Polycarbonate Lens  
L70 Life 150,000 Hours  
Warranty 10 Years  
CRI 70+  
Qualification UL, DLC 5.1, FCC, CE, RoHS  
Chip Man. Philips  
Whip Length (ft) 2'

## Electrical

Power Factor 0.9  
Frequency 50/60 Hz  
Max THD 12%  
Operating Temp. -40° F to 130° F  
-40° C to 54° C  
Dimming 0-10V

LED WALL PACK DECADE SERIES

## Ordering Information

ORDERING/DLC #:	Wattage	CCT	Lumens	Equivalent
U-IWP-28-30	28W	3000K	3,500 lm	125W MH
U-IWP-28-40	28W	4000K	3,612 lm	125W MH
U-IWP-28-50	28W	5000K	3,724 lm	125W MH
U-IWP-40-30	40W	3000K	5,000 lm	200W MH
U-IWP-40-40	40W	4000K	5,160 lm	200W MH
U-IWP-40-50	40W	5000K	5,320 lm	200W MH
U-IWP-60-30	60W	3000K	7,474 lm	250W MH
U-IWP-60-40	60W	4000K	7,680 lm	250W MH
U-IWP-60-50	60W	5000K	7,800 lm	250W MH
U-IWP-90-30	90W	3000K	11,366 lm	400W MH
U-IWP-90-40	90W	4000K	11,700 lm	400W MH
U-IWP-90-50	90W	5000K	11,880 lm	400W MH

## Additional Notes

- 4000K and 5000K, 100-277V are stocked locally, check for ETA's
- Altech Electronics reserves the right to make periodic improvements to our product specs

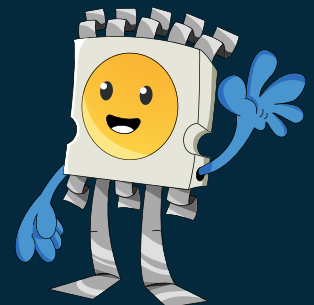

## Accessories and Options



Compatible with controls and integrations



Phenix Internal Emergency Inverter (18470X-2) (optional)

## Fixture Dimensions and Weight

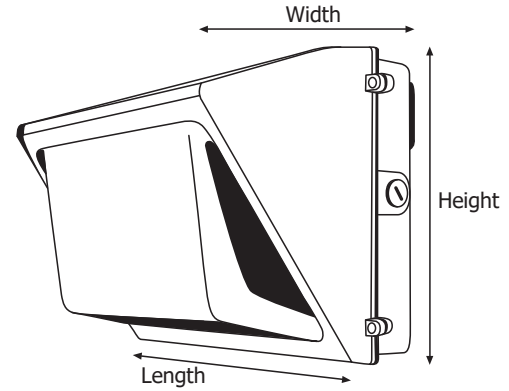

Length	Width	Height	Weight
14 in.	7.5 in.	9 in.	10.7 lb.
365 mm.	191 mm.	229 mm.	4.8 kg.

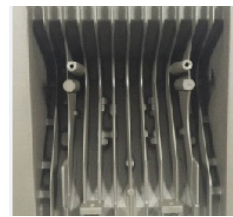

External heat sink designed specifically for this wall pack. Not only does it extend the life span, but also makes it suitable for warmer locations.

## Installation

1. Disconnect all power sources (**VERY IMPORTANT**).
2. Loosen/Unscrew the holding screws and back plate with rubber gasket.
3. Thread SO cord through rubber gasket and connect the wires correctly (via waterproof connectors)  
**Brown is live. Blue is neutral. Green/Yellow is ground.**
4. Mount the back plate with rubber gasket on wall with expansion screws.
5. Mount the fixture on the back plate.
6. Tighten the bottom holding screws and level appropriately.
7. Installation complete.



Refer to step 3.

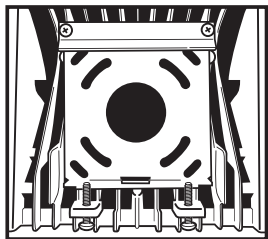

Refer to step 5.

